

1150 Open-Top Hopper Railcar

This open-top hopper railcar has a steel stub-sill underframe, with steel outside stakes welded to the sides and a pair of mechanically operated steel doors. This railcar is designed for iron ore service and may be bottom dumped or individually rotary dumped.



THE GREENBRIER COMPANIES

One Centerpoint Drive, Suite 200
Lake Oswego, Oregon 97035

info@gbx.com

DIMENSIONS (APPROX.)

Length, inside	19' -1 1/8"
Length, over couplers	24'
Height, inside	N/A
Height, extreme	11'
Clearance	AAR Plate B
Width, inside	10'
Width, extreme	10'-8"
Door opening, width	N/A
Height, top of rail to threshold	N/A

WEIGHT/CAPACITY (EST.)

Light weight	47,000 lbs.
Load limit	173,000 lbs.
Gross rail load	220,000 lbs.
Capacity	1,150 cu.ft.

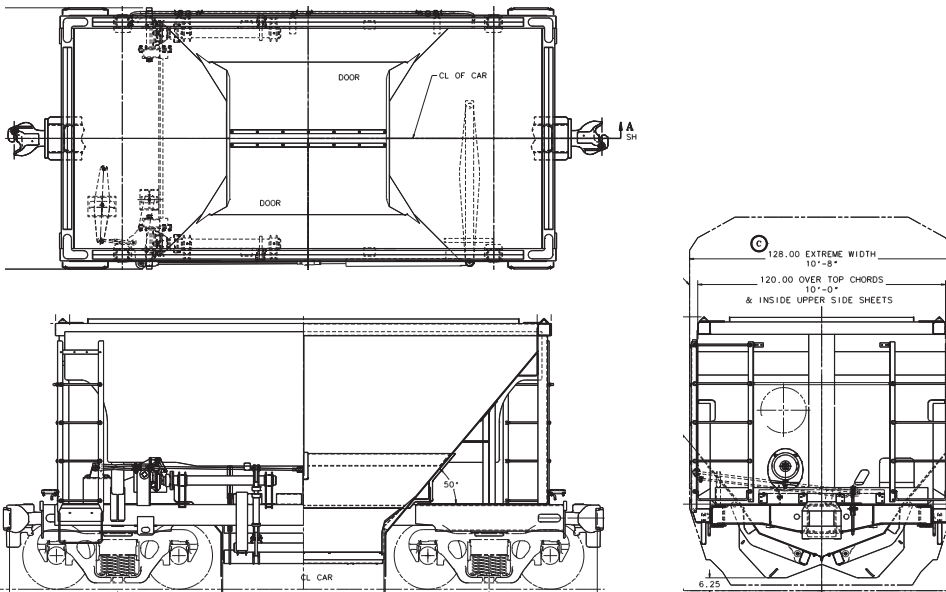

These general dimensions are representative and subject to change without notice.