

## 5-Trough Transverse Coil Gondola

Greenbrier's transverse coil steel gondolas are designed to remove interior rails and running boards, eliminate the need for dunnage and coil blocks—increasing worker safety and preventing coil damage. The gondola is available with 5- or 10-troughs and features bunk lining to prevent coil movement. Greenbrier's unique design offers the greatest shipment flexibility within the industry, fitting all available and future coil sizes. The optional cover is designed and built to optimally protect coils housed within a transverse style gondola and sloped to withstand rain and snow.



**THE GREENBRIER COMPANIES**

One Centerpointe Drive, Suite 200  
Lake Oswego, Oregon 97035

info@gbx.com

DIMENSIONS (APPROX.)	
Length, inside	N/A
Length, over couplers	44'-6 1/8"
Height, inside	N/A
Estimated cover roof height	12'-5 1/4"
Clearance	AAR Plate C
Width, inside	9'-2 3/4"
Width, extreme	10'-3"
Door opening, width	N/A
Height, top of rail to threshold	N/A

WEIGHT/CAPACITY (EST.)	
Light weight*	N/A
Load limit	234,100 lbs.
Gross rail load	286,000 lbs.
Capacity	40"–90" coils

CURVE NEGOTIABILITY RADIUS	
Uncoupled	150'
Coupled to base car	181'
Coupled to like car	172'

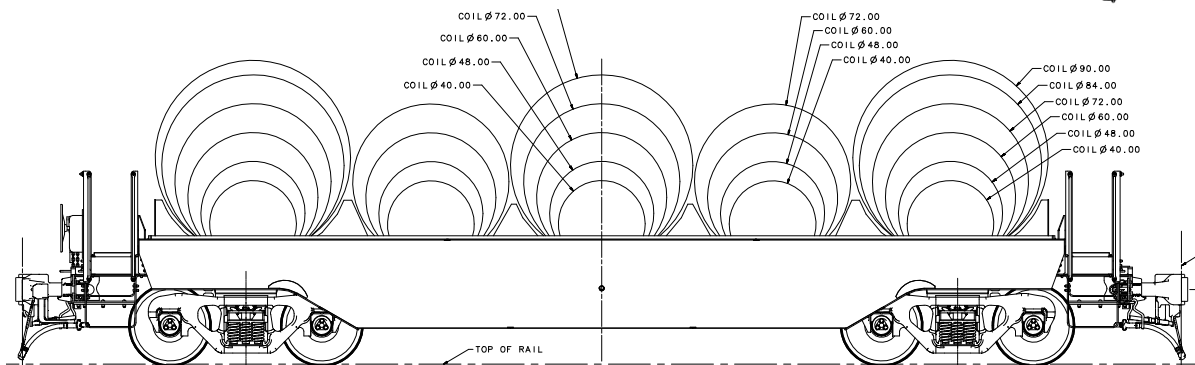
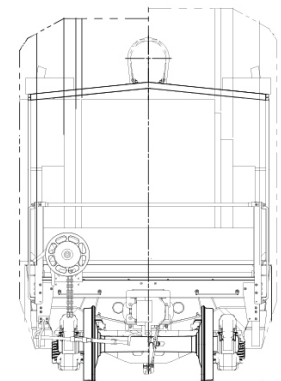

\* Does not include cover weight.  
These general dimensions are representative and subject to change without notice.