

MODEL 5126 Gravity-Pneumatic Outlet

SERVICE BULLETIN

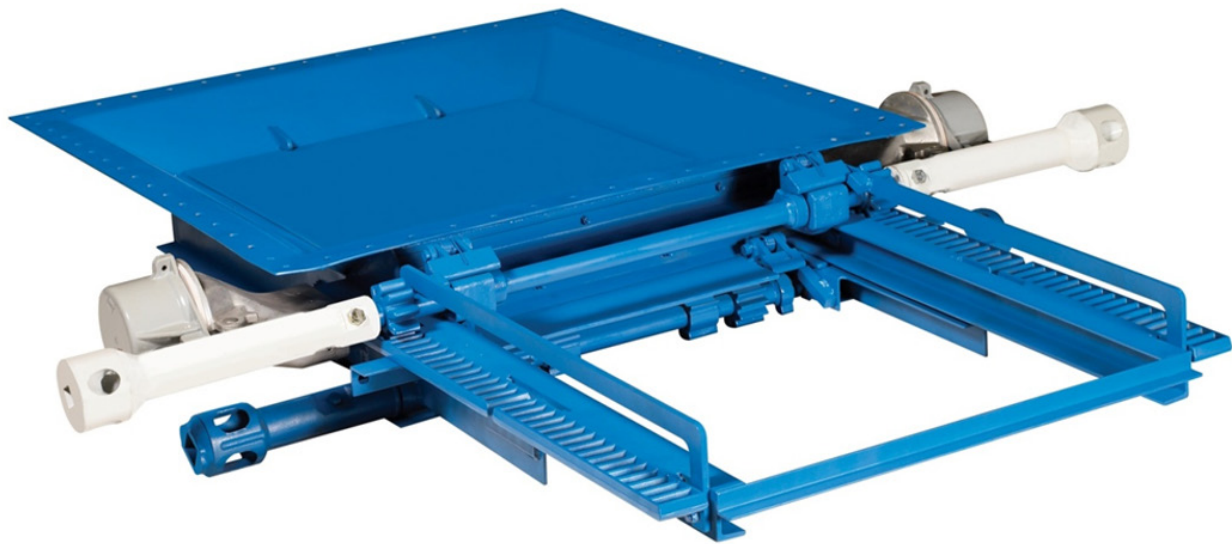

THE GREENBRIER COMPANIES
One Centerpointe Drive, Suite 200
Lake Oswego, Oregon 97035
info@gbrx.com

www.gbrx.com

THE
GREENBRIER
COMPANIES

July 10, 2023

The Center Flow® Gravity-Pneumatic Outlet was designed to meet the demand for a combination outlet providing unobstructed gravity discharge and complete pneumatic flow. This outlet assures instant car versatility to meet varied unloading patterns. Yet, there is no compromise of efficiency to provide this flexibility—you get full flow with either type discharge.

Faster Gravity Discharge

Conventional Gravity-Pneumatic outlets were at best compromises because of the obstructed gravity flow and inefficient pneumatic clean-out. Departing from the standard technique of placing a pneumatic intake hood and tube over the gravity gate, the pneumatic outlet is mounted completely outside the gravity discharge area. This design is at least five times more effective in preventing bridging of lading than other combination outlets. It provides between-rail unloading at rates as rapid as the straight gravity outlet.

Full Clean-out Pneumatic Discharge

Location of the pneumatic intake beneath the gravity gate provides effective air control over the full length and width of the outlet. Result: you get maximum flow rate and full clean-out; not just with the more powerful systems but with almost any pneumatic unloading system.

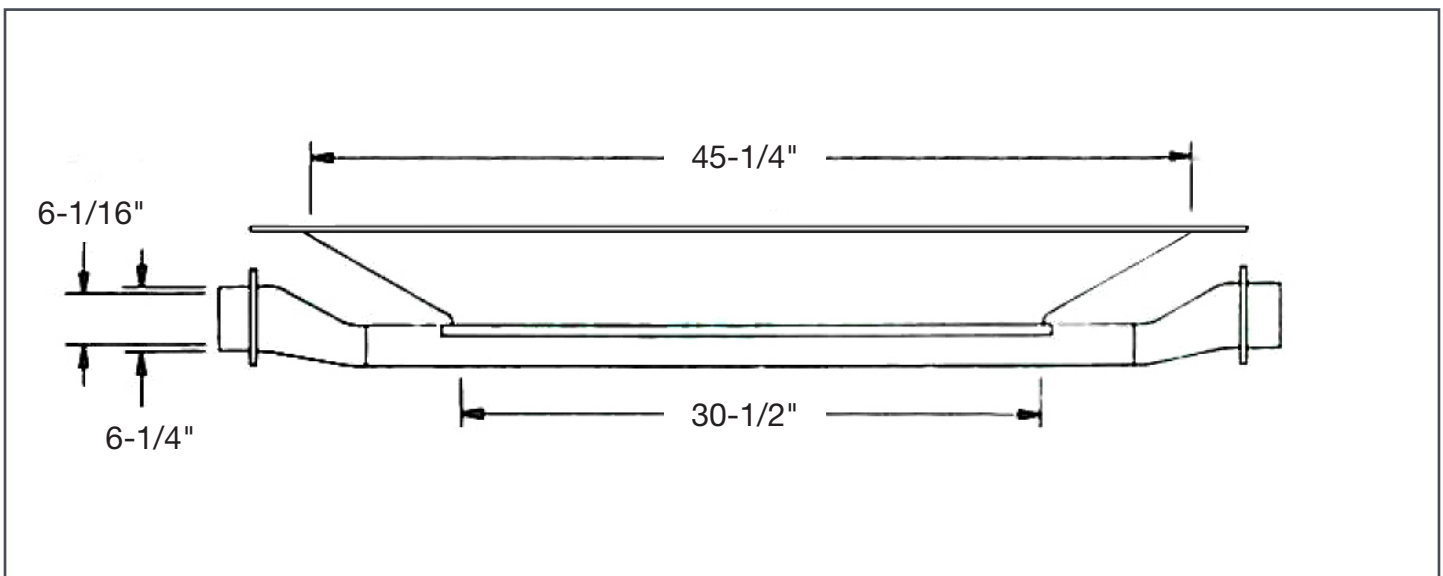

OPERATING INSTRUCTIONS

The combination Gravity-Pneumatic outlet contains two discharge systems. Either can be employed depending on the consignee's facilities.

Gravity Discharge

1. Open one hatch on the compartment to be unloaded.
2. Open the sanitary shield by placing a bar in the sanitary shield capstan and rotating until the sanitary shield locks in the "open" position.

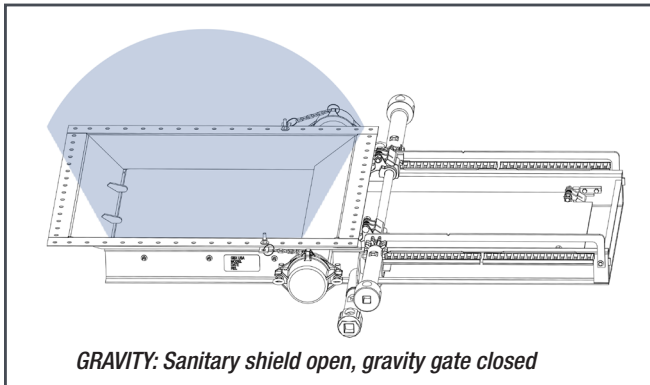

3. Release the lock. Then open the gravity gate by rotating the operating shaft with a lever. The position of the gravity gate will determine the rate of discharge. Open completely for maximum flow.

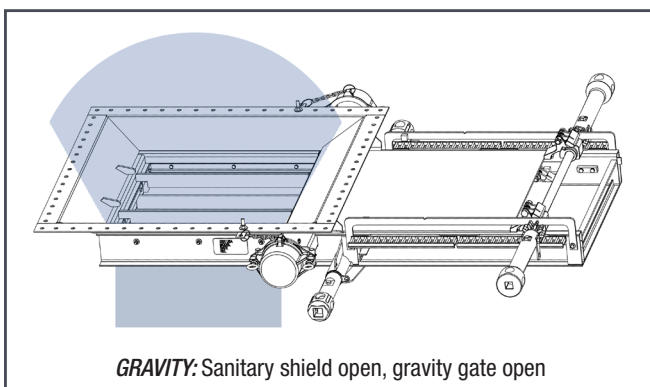

4. After discharge is complete, close and lock the gravity gate, then close and lock the sanitary shield. Close the hatch.

Pneumatic Discharge

1. Open one hatch on the compartment to be unloaded.
2. Loosen the cap retaining screws and open the caps on both sides of the outlet.

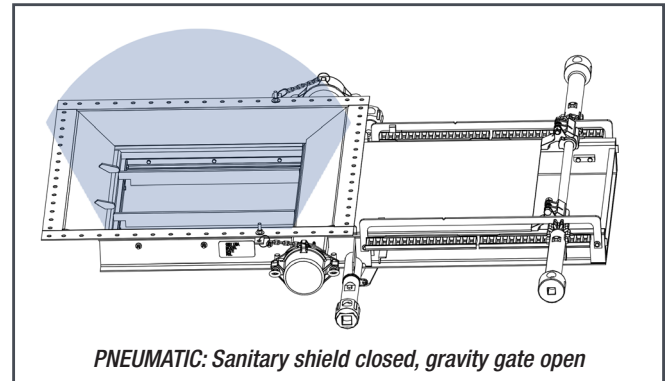

3. Connect a pneumatic discharge line equipped with a bleed air valve to the pneumatic nozzle.
4. Open the gravity gate to the full open position.
5. Start the vacuum system; adjust the bleed air valve to obtain the desired flow rate.

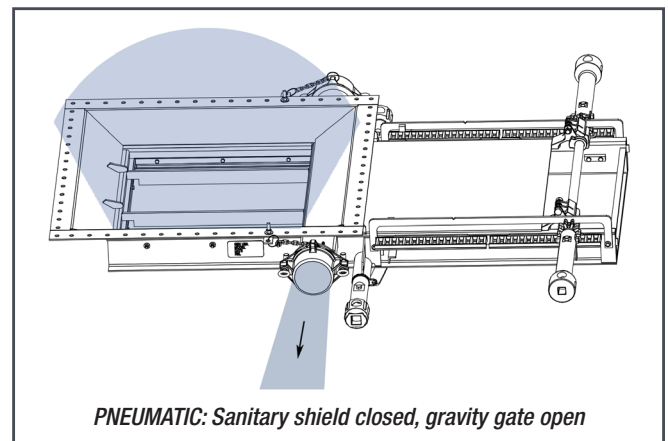

6. When the material flow ceases, close the bleed air valve.
7. Slowly close the gravity gate to clean out the residual lading from the hopper.
8. Shut down the vacuum system and disconnect the pneumatic line.
9. Replace and secure the nozzle caps and close the hatch.

CAUTION: If filtered air is required, apply filter(s) to open hatch(es) and to the nozzle opposite the one used for vacuum connection.

Pre-trip Inspection

Secure the Outlet Prior to Loading

Outlets should be inspected to verify that they are functional and clean. Outlet caps should be inspected for cleanliness, gasket integrity, and damage. Outlet caps must be securely locked and sealed prior to shipping the car.

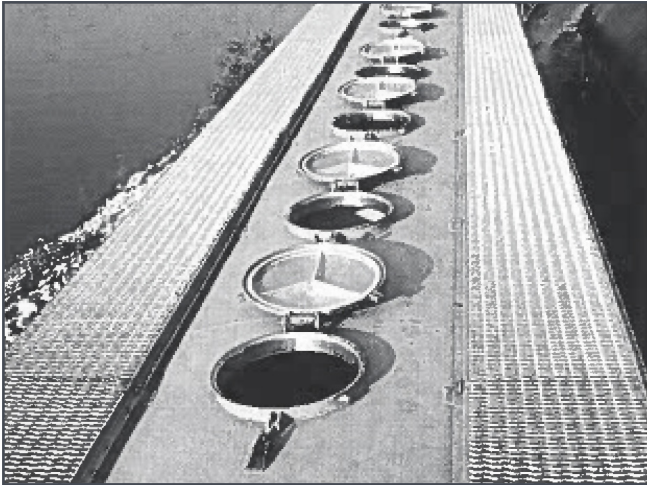

Wipe hatch rings, covers, and gaskets clean to assure proper sealing of covers.

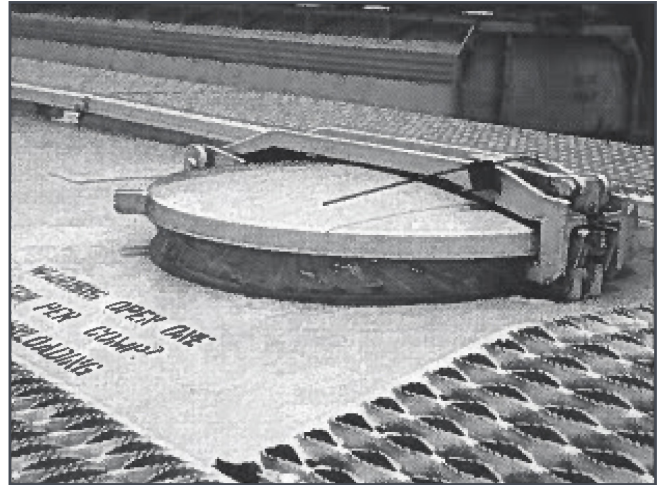

Properly applied seal through the hatch strap and over the cam lever. As can be readily seen, it would be impossible to open the hatch without breaking the seal.

Preparing an Empty Car

Replace and secure outlet caps on both sides of car.

The AAR requires that all outlets be closed and secured before an empty covered hopper car is routed back to a loading facility. This simple action will prevent damage and costly replacement or repairs to the outlets.