

# ARI1108 & HP1108 Safety Relief Valve

## INSPECTION & MAINTENANCE BULLETIN

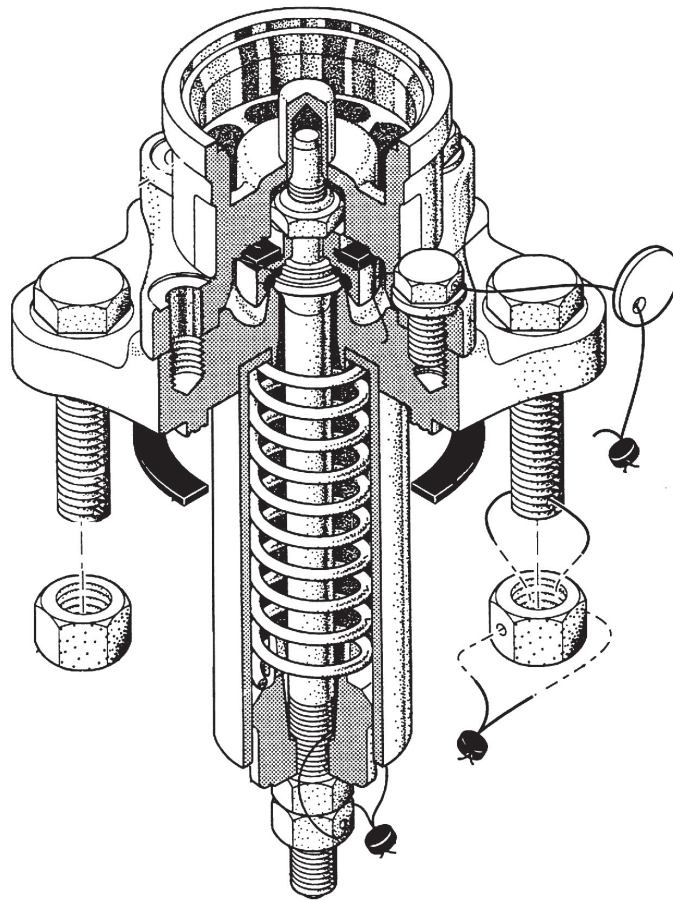

These instructions are applicable to the following models:  
ARI1108  
ARIHP1108

Only facilities with AAR Activity Code C5 are certified to recondition, repair, retest and qualify tank car safety relief valves. Personnel performing inspection and test must be certified to a minimum of Level II per AAR Manual of Standards and Recommended Practices, M-1002

THE GREENBRIER COMPANIES  
One Centerpointe Drive, Suite 200  
Lake Oswego, Oregon 97035  
info@gbrx.com

*THE*  
**GREENBRIER**  
*COMPANIES*

[www.gbrx.com](http://www.gbrx.com)

Original Date: October 5, 2020  
Revision Letter: C  
Revision Date: June 1, 2026

## New Valves for Replacement of Existing Equipment

New valves are tested, sealed and packaged at the time of manufacture. A new valve can be applied provided it is still in its original packaging and tested within 6 months of the installation date. A valve with a test date older than 6 months must have the O-rings replaced and retested.

**Safety relief valves are spring loaded devices that can store a significant amount of energy. Assembly and disassembly must be performed by trained, qualified personnel.**

### Disassembly Procedure

#### Disassembly of the spring and guide

1. Remove the 2 seal wires, items #9.
2. Clean the stem threads with a wire brush and lubricate the threads with a light oil, like WD-40.
3. Using two wrenches, one applied to adjustment nut and the other to the locknut, item #11, loosen and remove the locknut. Ensure the stem does not rotate or damage to the seat may occur.
4. Measure and record the distance from the end of the stem to the spring adjustment nut. This dimension is required and will be used during reassembly.
5. Place the valve into a press with the spring in the upward position.
6. Using a press yoke to allow access to the stem adjustment nut, compress the valve spring to remove all force from the nut. Remove the stem adjustment nut. Ensure the stem does not rotate or damage to the seat may occur.
7. Slowly release the press until the valve spring, item #14, expands to the relaxed state.
8. Remove the spring follower, item #13, the spring guide, item #15, and the spring, item #14.
9. Place the valve assembly onto a valve workstation.

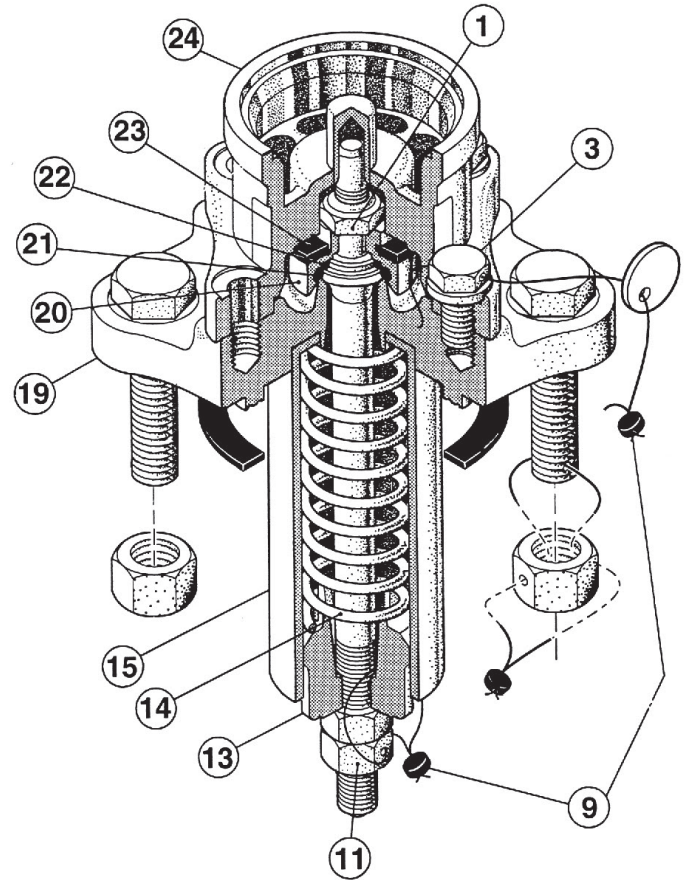

#### Disassembly of the Top guide, Stem and O-ring Retainer

1. Remove the four bolts, item #3, securing the top guide, item #24 to the valve body, item #19.
2. Lift off the top guide, item #24. It may be necessary to loosen the guide by tapping with a mallet.
3. Once removed, secure the stem in a vise with non-marring clamps or another suitable device to ensure the stem won't be damaged.
4. Peel off the bumper washer, item #23.
5. Using two wrenches, one applied to the hex on the retainer, item #20, and the other to the locknut, item #1, loosen and remove the locknut.
6. Remove the O-ring retainer with the use of a wheel puller or gently prying under and around the lip with a screwdriver.
7. Using a packing removal pick, remove the O-rings, items #21 & 22, from the retainer taking care not to mar the O-ring grooves.
8. Turn the valve body over and using a packing removal pick or a thin blade screwdriver, pry the gasket, if attached, from the gasket face. Take care not to mar the sealing surface.

# Inspection of Valve Components

## Top Stem Guide

The inside of the top stem guide should be free of paint, debris, nicks, burrs or other discontinuities. Visually inspect the inside of the guide and the mating area on the upper stem. Any sign of significant wear should be reported to GBX Engineering for review and disposition.

## Valve Stem

Remove all scale, residue and other foreign material from the stem with a wire brush. Inspect the stem for signs of corrosion or pitting. Any evidence of corrosion or pitting is grounds for replacement.

The seating surface and O-ring contact areas can be cleaned with 400 grit emery cloth. Any discontinuity that would prevent sealing is grounds for replacement. Machining, grinding, welding or other alterations are not permitted.

The stem must be inspected between the threaded sections for cracking using either magnetic particle or dye penetration inspection methods. Cracking is unacceptable. If found, the stem must be replaced.

Place the stem in a set of V-blocks and measure straightness with a dial indicator. The stem must be straight within .015 TIR. If out of tolerance, the stem must be replaced. Straightening by bending or heat is not permitted.

## O-Ring Retainer

Clean the O-ring setting surfaces inside the retainer with 400 grit emery cloth. Visually inspect the O-ring grooves. They must be free of pits, corrosion or gouges that would prevent proper sealing of the O-rings.

## Valve Body

The area around the valve seat must be free of debris, corrosion and foreign objects. Cleaning can be accomplished with a light brush off blast using glass bead media. The seating surface must be free of nicks, burrs and gouges. The area should be cleaned and lightly polished with 400 grit emery cloth. Any discontinuity that would prevent the valve from sealing is grounds for replacement. Machining, grinding, welding or other alterations are not permitted.

Turn the valve body over to inspect the mounting flange and gasket groove. The gasket groove must be free for residual gasket material, corrosion, nicks, burrs and gouges. Any discontinuity that would prevent sealing is grounds for replacement.

## Valve Spring

Remove all scale, residue and other foreign material from the spring with a wire brush. Inspect the spring for signs of corrosion or pitting. Any evidence of corrosion or pitting is grounds for replacement.

The spring must be inspected for cracking using either magnetic particle or dye penetration inspection methods. Cracking is unacceptable. If found, the spring must be replaced.

Stand the spring upright on a level surface. Place a straight edge against the outside and measure for straightness. Turn the spring 90 degrees and measure again. The spring must be straight within  $\frac{1}{4}$ ". If out of tolerance, the stem must be replaced.

Aluminized springs cannot be inspected with magnetic particle or dye penetration methods. After cleaning, visually inspect the coating. Any evidence of peeling or flaking of the aluminum is grounds for replacement.

## Spring Guide

Remove all scale, residue and other foreign material from the guide with a wire brush. Inspect the guide for signs of corrosion or pitting. If any is found, the guide must be replaced.

Inspect the interior of the guide for signs of wear caused by the spring follower. Wear could be an indication of a bowed spring, misassembled spring or misalignment of the valve with the safety valve nozzle. If wear is noted, measure the outside diameter in the affected area then at 90 degrees. Compare the readings. If the difference exceeds 0.030" replace the spring guide.

## Spring Follower

Remove all scale, residue and other foreign material from the stem with a wire brush. Inspect the follower. Any evidence of corrosion or pitting is grounds for replacement.

Visually inspect the outside diameter of the follower for signs of significant wear. Wear could be an indication of a bowed spring, misassembled spring or misalignment of the valve with the safety valve nozzle. If wear is noted, measure the inside diameter in the affected area then at 90 degrees. Compare the readings. If the difference exceeds 0.030" replace the spring follower.

## O-Rings

O-rings must be replaced any time the retainer is removed from the stem.

## Assembly Procedure

1. Install the O-rings in the O-ring grooves of the O-ring retainer taking care not to tear, stretch or otherwise damage the O-rings. Sharp tools should never be used for this operation. Do not roll the O-ring on to the retainer.
2. Place stem in suitable fixture making sure to prevent damage and apply retainer with O-rings onto the stem. Do not roll the O-ring on to the retainer.
3. Install the locknut on the stem with a wrench applied to the hex on the retainer and screw that one to the nut. Torque to 30 ±5 ft-lbs.
4. Install the bumper washer on the retainer.
5. Place valve body in fixture and install stem taking care not to damage stem or seat areas.
6. Align top guide with valve body fastener holes, apply fasteners. Torque to 30 ± 5 ft-lbs. (if applicable, place seal hole fasteners next to each other).
7. Place the valve in the press ensuring the spring is seated in the body and the stem is aligned. Install the spring and spring follower then position the yoke and compress the spring enough to apply the adjustment nut. With the nut fully engaged, further compress the spring and tighten the nut to the previously recorded dimension from the nut to the end of stem.
8. Move valve to the test stand.
9. After testing is complete, install the stem locknut and use two wrenches, tighten to 30 +/- 5 ft-lbs.
10. Install new seal wires, item #9.

## Guidelines for Testing and Adjustment

### Determining Applicable Pressure Values

The ARI1108 safety relief valve is designed to operate at 75 psig. The start-to-discharge pressure (STD) must be 75 psig +/- 3 psig and vapor-tight at 60 psig minimum.

The ARIHP1108 safety relief valve is designed to operate in a range from 225 psig to 330 psig. The start-to-discharge pressures (STD) are as follows:

Start-to-Discharge Pressure (psig)	Tolerance (psig)	Vapor-Tight Pressure (psig)
225	6.75	180
247.5	7.4	196
255	7.7	204
280.5	8.4	224
300	9.0	240
330	10.0	264

## Test Stand and Gauge Requirements

The test stand must have a mounting that complies with AAR M-1002, Section C-III, Appendix E, Figure E21 A. Test stand pressure gauge must meet the requirements of AAR M-1002, Section C-III, Appendix D section 4.5, Test Gauge Standards. Gauges must be date tagged.

## Testing Procedure

1. Safety Relief Valve Start to discharge and vapor tight tests must be conducted in accordance with AAR M-1002, Section C-III. Personnel performing valve testing must be an NDT Leak Test Level II or III.
2. Apply the safety valve to the test stand.
3. Plug the valve body drain opening using putty or a foam ear plug.
4. Increase pressure under the valve until the valve starts to discharge and note pressure (recommended to perform twice, this will give a good estimate of where the start to discharge (STD) pressure will be during liquid test).
5. Fill the chamber to the top of the stem guide with water.
6. Begin slowly increasing pressure under the valve until the first bubble appears. This is the STD and must be within the tolerances provided in the previous section, Guidelines for Testing and Adjustment.
7. If the start-to-discharge pressure falls outside the specified range, adjust the valve spring by tightening the adjustment nut to increase the discharge pressure and loosen to decrease. Repeat Steps 4-6.
8. NOTE: If adjusting the spring tension produces the opposite of the desired effect, the spring could be defective and must be replaced.
9. Once the proper start-to-discharge pressure is attained, slowly decrease the pressure until the bubbles stop. This is the vapor tight pressure and must be within the tolerances provided in the previous section, Guidelines for Testing and Adjustment.
10. A vapor-tight pressure falling below the specified minimum could indicate a problem with the O-rings not sealing properly. Release all pressure from under the valve and remove the O-ring Retainer following the instructions under "Disassembly of the Top guide, Stem and O-ring Retainer", steps 1-7. Reassemble per instructions under "Assembly Procedure", steps 1-6.
11. Visually inspect the O-rings for nicks, gouges or improper setting in the retainer. Visually inspect the seating surface. A fingernail run across the surface can pick up discontinuities that are not readily visible. Any defect must be corrected.
12. Once the start-to-discharge and vapor-tight pressures are attained, test a second time to confirm the settings then tighten the stem locknut and install the seal wires per steps 9 & 10 in the Assembly Procedure section.
13. After testing is complete and adjustments as necessary, install the stem locknut and use two wrenches, tighten to 30 +/- 5 ft-lbs.
14. Apply identification tags and CID information per AAR M-1002, Section C-III.

The undertaking of repair or replacement by the Purchaser, or its agents, without the expressed written consent of The Greenbrier Companies (GBX) shall void the warranty and relieve GBX of all responsibility. Under no circumstances shall GBX be liable for any direct, incidental, consequential or other damages of any kind in connection with the installation, operation, maintenance, repair, inspection or other use of any product purchased from it.